



Stabilitätspakt für Südosteuropa
Gefördert durch Deutschland
Stability Pact for South Eastern Europe
Sponsored by Germany

International PhD-Seminar

Numerical Field Computation and Optimization in Electrical Engineering

**Proceedings
of
Full Papers**

20-25 September 2005
Ohrid
Macedonia

Издавач:
ЕЛЕКТРОТЕХНИЧКИ ФАКУЛТЕТ СКОПЈЕ
П. фах. 574, 1000 Скопје, Македонија

Главен и одговорен уредник:
Асистент д-р Весна Арнаутовски Тошева

Стручен уредник:
Проф. д-р Велимир Филипоски

Техничка обработка:
Асистент инж. Соња Филипоска

CIP – Каталогизација во публикација
Народна и универзитетска библиотека „Св. Климент Охридски“, Скопје

621.3.(062)
537(062)

NUMERICAL Field Computation and Optimization in Electrical Engineering :
International PhD-Seminar, 20–25 September 2005,
Ohrid, Macedonia : Proceedings of Full Papers, – Skopje :
Електротехнички факултет, 2005, – 220 стр.; 24 cm

ISBN 9989–630–47–x

а) Електротехника – Собири б) Електромагнетизам – Собири
COBISS.MK-ID 61960458

Тираж: 60 примероци, 2005 год.

CONTENTS

Milenko ADAMOVIC, Milica RANCIC FEMLAB MODELLING: APPLICATION IN EDDY-CURRENT NON-DESTRUCTIVE TESTING.....	1
Milica ANGELOVA, Vesna ARNAUTOVSKI-TOSEVA and Leonid GRCEV COMPARISON OF EXACT AND IMAGE MODEL OF GROUNDING SYSTEMS-----	5
Miroslav BJEKIC NUMERICAL COMPUTATIONS DINAMIC CHARACTERISTICS OF PERMANENT-MAGNET STEP MOTOR.....	11
Dijana BORISOV SURFACE CHARGE DISTRIBUTION IN CYLINDRICAL CAVITY.....	17
Kostadin BRANDISKY CAD SYSTEMS IN ELECTROMAGNETICS AND RECENT ADVANCES IN THE FINITE ELEMENT METHOD	21
Hartmut BRAUER OPTIMIZATION TECHNIQUES FOR ENGINEERING DESIGN PROBLEMS	33
Grigore A. CIVIDJIAN SOME FORMULAS FOR PARTIAL CAPACITANCES.....	45
Nenad N. CVETKOVIC LINEAR GROUNDING SYSTEMS: QUASI-STATIONAR STRUCTURE OF HERTZ'S VECTOR AND ELECTRIC SCALAR POTENTIAL	55
Milan M. DOBRICIC NUMERICAL SOLVING ELECTROSTATIC PROBLEMS WITH CONFORM MAPPING	61
Alin-Iulian DOLAN, Ivan YATCHEV and Krastio HINOV STATIC FORCE CHARACTERISTICS OF A PLUNGER-TYPE ELECTROMAGNET	67
Ivaylo DOLAPCHIEV LVDT SHAPE OPTIMIZATION USING GENETIC ALGORITHM	73
Sonja FILIPOSKA , Leonid GRCEV TIME ANALYSIS OF THE CURRENT DISTRIBUTION ALONG A TOWER SUBJECTED TO A PULSE EXCITATION.....	79
Dragan FILIPOVIĆ NETWORK MODELING OF PLANE-WAVE SCATTERING FROM METAL GRATINGS	83
Ogdenka GAVRILOSKA, Mircev Miroslav, Vesna ARNAUTOVSKI-TOSEVA and Leonid GRCEV APPROXIMATIVE IMAGE FORMULATION FOR THE FIELDS OF A HORIZONTAL HERTZIAN DIPOLE IN HOMOGENOUS SOIL.....	89
Leonid GRCEV HF MODELING IN THE PRESENCE OF EARTH.....	95
Saša S. ILIĆ SLIT COAXIAL LINE	107

STATIC FORCE CHARACTERISTICS OF A PLUNGER-TYPE ELECTROMAGNET

Alin-Iulian DOLAN¹, Ivan YATCHEV² and Krastio HINOV³

Abstract: In the paper, the static force characteristics of a plunger-type electromagnet are obtained. Numerical modelling using 3D finite element method is employed. Two formulations – with magnetic scalar potential and with edge elements – are used. Comparison is made with experimental results and error estimation is given.

Keywords: Electromagnetic force, Numerical computation, FEM, 3D fields, Electromagnet

INTRODUCTION

Being important elements between electrical and mechanical systems in many modern applications, the electromagnets often require optimal design for certain force, displacement and time characteristics assurance.

Three-dimensional electromagnetic force computation is subject of permanent interest for researchers in recent years [1-6].

In the paper, the electromagnetic force of plunger-type electromagnet is obtained using different approaches implemented in ANSYS[®] program [7]. Experimental values of the static electromagnetic force, for a range of air gaps and different magnetomotive forces (m.m.f.) are also obtained and compared with the computed values using the different approaches.

NUMERICAL COMPUTATION APPROACHES

Two formulations for analysis of the 3D static magnetic field have been employed – magnetic scalar potential and edge element formulation. For the magnetic scalar potential formulation, the electromagnetic force is computed using the Maxwell stress tensor approach and using the virtual work approach. For edge element formulation, the force is computed using the virtual work approach.

The magnetic scalar potential (MSP) formulation allows to simply model current sources as primitives rather than elements and so, these do not need to be part of the finite element mesh. In the edge element the current sources (current conducting regions) are considered as an integral part of the finite element model. The edge formulation associates degrees of freedom with element edges rather than element nodes. The edge element formulation is often considered as better than the

nodal based magnetic vector potential formulation in the cases of presence of media of different properties.

The Maxwell stress tensor approach is one of the two approaches used to determine the force on the plunger using MSP formulation. The force is computed by performing integration of the Maxwell stress tensor \mathbf{T} over a surface in the air around the plunger. If \mathbf{n} denotes the unit outward normal to the enclosing surface S , the force is obtained by

$$\mathbf{F} = \oint_{(S)} \mathbf{T} \cdot \mathbf{n} dS. \quad (1)$$

The components of the Maxwell stress tensor are defined using the flux density B and its components along the three co-ordinate axes:

$$\{T\} = \frac{1}{\mu_0} \begin{pmatrix} B_x^2 - \frac{1}{2} B^2 & B_x B_y & B_x B_z \\ B_y B_x & B_y^2 - \frac{1}{2} B^2 & B_y B_z \\ B_z B_x & B_z B_y & B_z^2 - \frac{1}{2} B^2 \end{pmatrix}, \quad (2)$$

where μ_0 is the permeability of free space

The second approach employed for obtaining electromagnetic force is the virtual work principle. The nodal forces are obtained as the derivative of the energy versus the displacement of the movable part. This calculation for MSP formulation is applied to a layer of air elements surrounding the movable part. To determine the total force acting on the body, the forces in the air layer surrounding it can be summed.

The basic equation for force of an air material element in the s direction is:

$$F_s = \int_v \{B\}^T \left\{ \frac{\partial H}{\partial s} \right\} dv + \int_v \left(\int \{B\}^T \{dH\} \right) \frac{\partial}{\partial s} dv \quad (3)$$

where: F_s is force in element in the s direction
 s is virtual displacement of the nodal coordinates taken alternately to be in the x, y, z global directions;

¹ Technical University of Sofia, French Language Department of Electrical Engineering, Bulgaria (on leave from University of Craiova, Department of Electrical Apparatus and Technologies, Decebal, 107, Craiova 200440, Romania), E-mail: adolan@elth.ucv.ro

² Technical University of Sofia, Department of Electrical Apparatus, 1156 Sofia, Bulgaria, E-mail: yatchev@tu-sofia.bg

³ Technical University of Sofia, Department of Electrical Apparatus, 1156 Sofia, Bulgaria, E-mail: k_hinov@yahoo.co.uk

$\left\{ \frac{\partial H}{\partial s} \right\}$ - derivative of field intensity with respect to displacement;
 v - volume of the element.

For the edge element formulation, the electromagnetic force is calculated on a selected set of nodes.

MODEL DESCRIPTION

For FEM and experimental verification, the model shown in Figure 1, with the dimensions given in the Table I, was used. The minimum value of the air gap is $\delta_{MIN} = 0.2$ mm, value imposed by an insulated material witch covers the bottom interior surface core. The magnetic core is made of laminated steel and the magnetisation curve B-H presented in Figure 2 was taken in account. The coil is excited by a DC current and its number of turns is $w = 11500$, having the electric

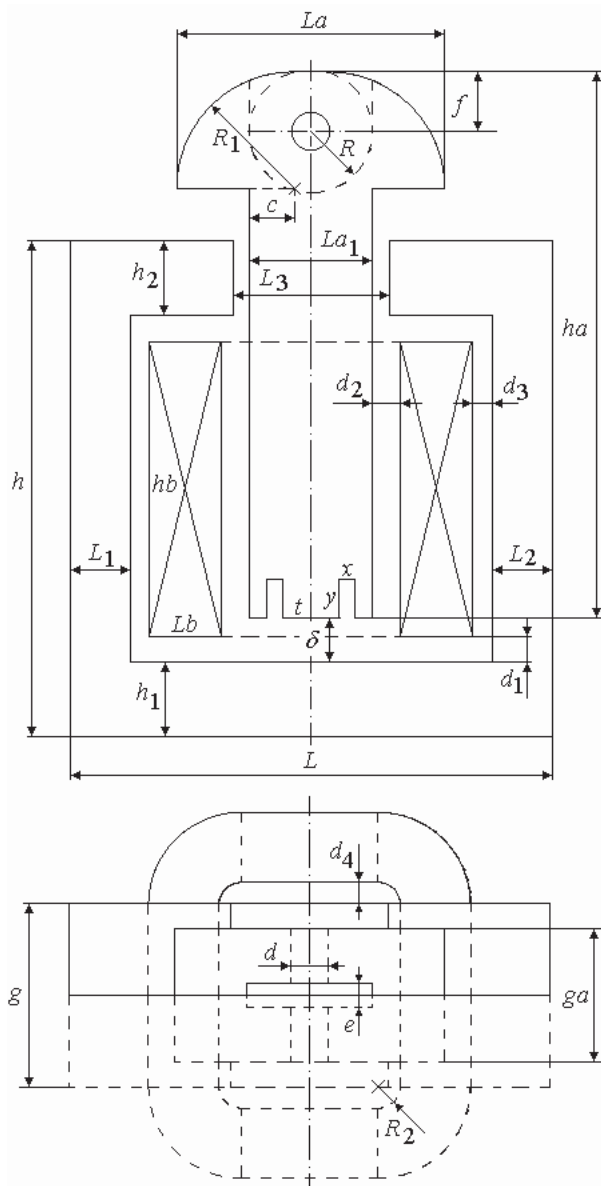

Fig.1 - Plunger-Type Electromagnet

Table I
 Dimensions of the electromagnet [mm]

<i>h</i>	52.5	<i>g</i>	19.8	<i>f</i>	6.30	<i>hb</i>	31.2
<i>h</i> ₁	7.90	<i>ha</i>	57.8	<i>R</i>	6.50	<i>Lb</i>	7.50
<i>h</i> ₂	7.90	<i>La</i>	28.3	<i>R</i> ₁	12.3	<i>d</i> ₁	2.40
<i>L</i>	50.9	<i>La</i> ₁	13.0	<i>ga</i>	14.3	<i>d</i> ₂	3.00
<i>L</i> ₁	6.35	<i>c</i>	4.65	<i>x</i>	1.60	<i>d</i> ₃	2.10
<i>L</i> ₂	6.35	<i>d</i>	4.00	<i>y</i>	4.20	<i>d</i> ₄	2.25
<i>L</i> ₃	16.5	<i>e</i>	2.60	<i>t</i>	6.00	<i>R</i> ₂	2.40

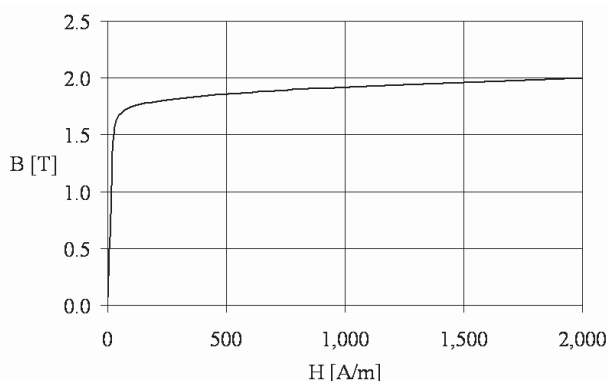

Fig.2 - B-H curve

resistance $R_B = 2300$ Ohm. The m.m.f. were chosen to be 345, 402.5, 460, 517.5 and 575 A (DC) in order to investigate the static force characteristics.

FEM AND EXPERIMENTAL VERIFICATION

The electromagnetic force was measured using tensosensor for a range of the air gap (δ) between 0.5 and 7.2 mm at the specified values of m.m.f. The experimental results are illustrated in Figure 3 and Figure 4, where the air gap and m.m.f. influences can be seen.

The numerical results of the 3-D static analysis have been obtained using ANSYS program, for each of the three approaches: MSP-Maxwell stress tensor, MSP-Virtual Work and Edge formulation. For automation of the numerical computation, a command file has been created using APDL (ANSYS Parameter Design Language). This allows multiple runs to be executed easy and changing any of the parameters is carried out only by changing a line in the command file.

The mesh was realised using tetrahedral elements. A half a model was analysed, a two-time reduction of work volume being obtained. The number of elements vary in range 56 000 - 76 000 and 67 000 - 123 000 in MSP, respectively edge computation, limited by hardware resources.

For m.m.f. value of 460 A, the numerical and experimental results are comparatively shown in Figure 5. In Figure 6, a comparison between selected data for a representative air gap $\delta = 0.89$ mm, can be seen .

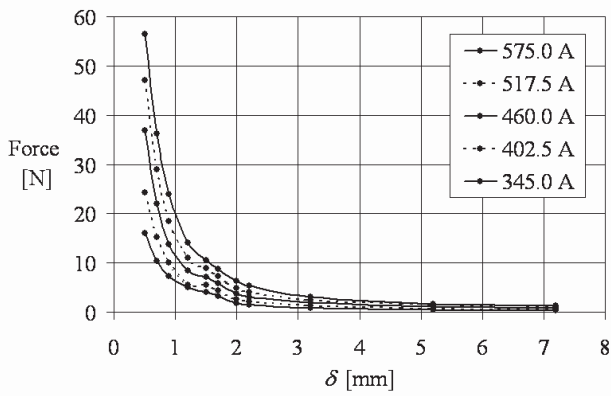

Fig.3 - Experimental force-stroke characteristics

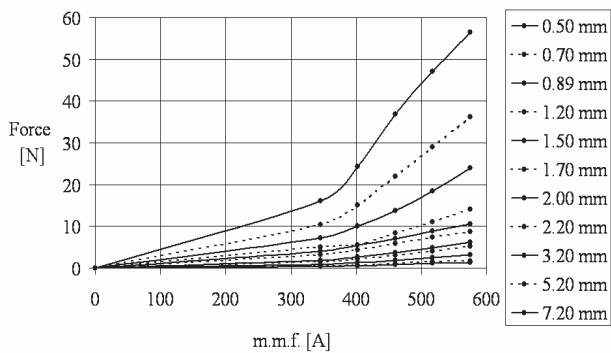

Fig.4 - Experimental force-current characteristics

Using the visualization facilities offered by ANSYS program, the Figures 7 - 10 show the 3D front and symmetry plane perspective of the model with associated mesh, corresponding to MSP and Edge formulations.

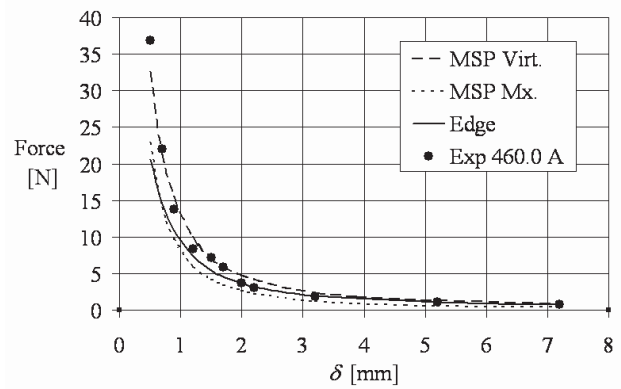

Fig.5 - Force-stroke characteristics for m.m.f. 460 A

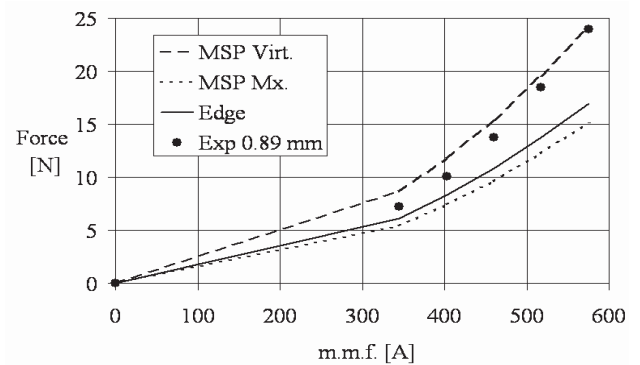

Fig.6 - Force-current characteristics for air gap 0.89 mm

The magnetic field density distribution on symmetry plane is shown in Figure 11 and the electromagnetic force vectors are plotted in Figure 12.

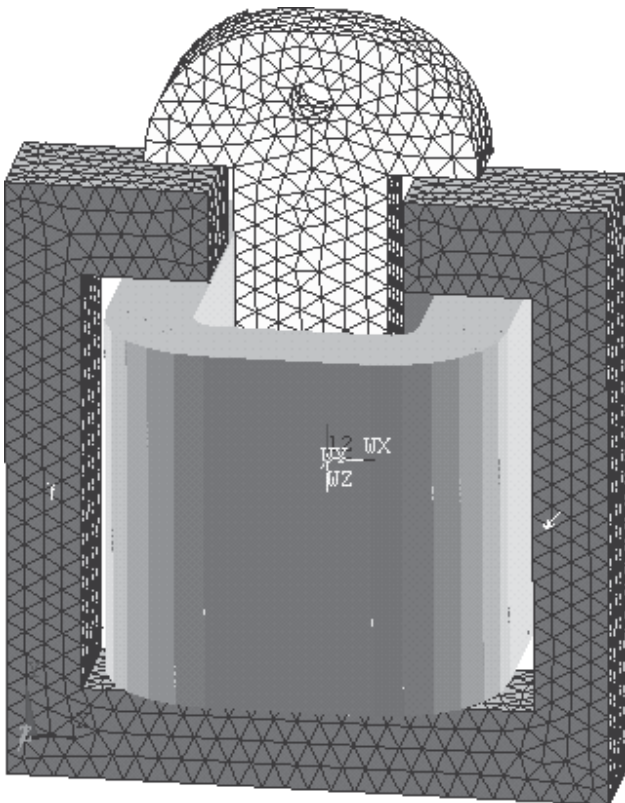

Fig.7 - Front-view mesh model building - MSP formulation

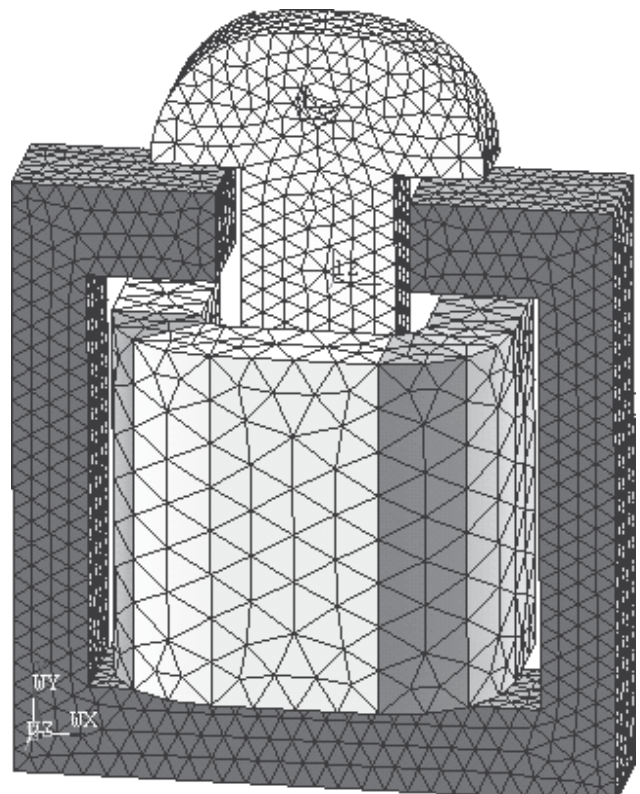

Fig.8 - Front-view mesh model building - Edge formulation

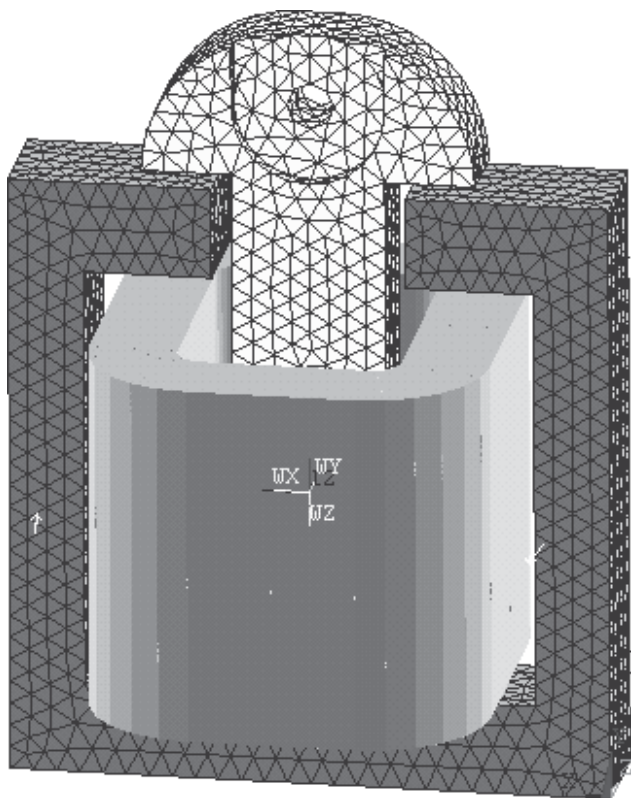

Fig.9 - Symmetry plane-view mesh model building
MSP formulation

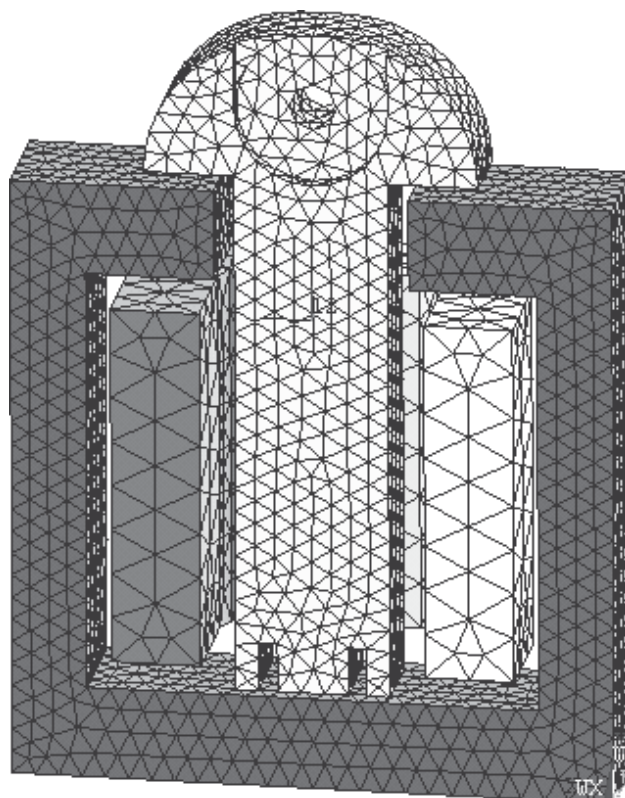
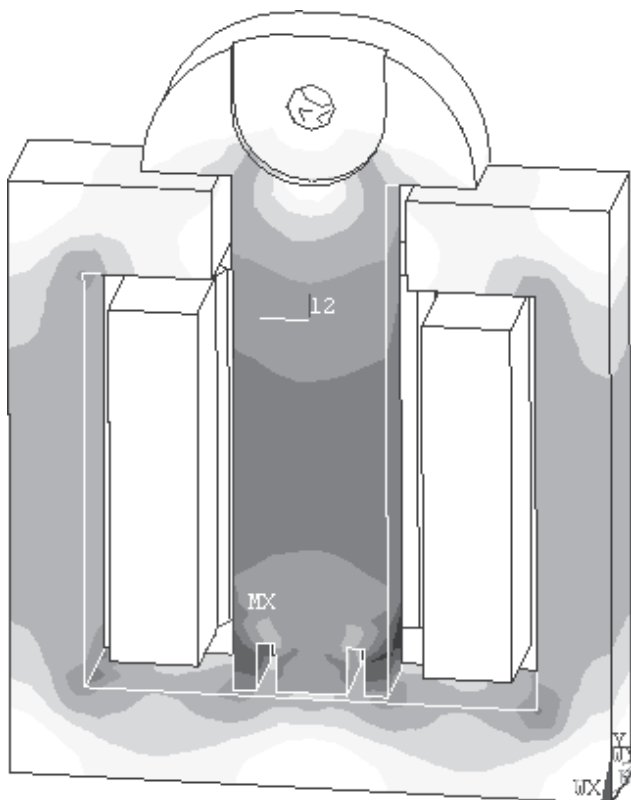
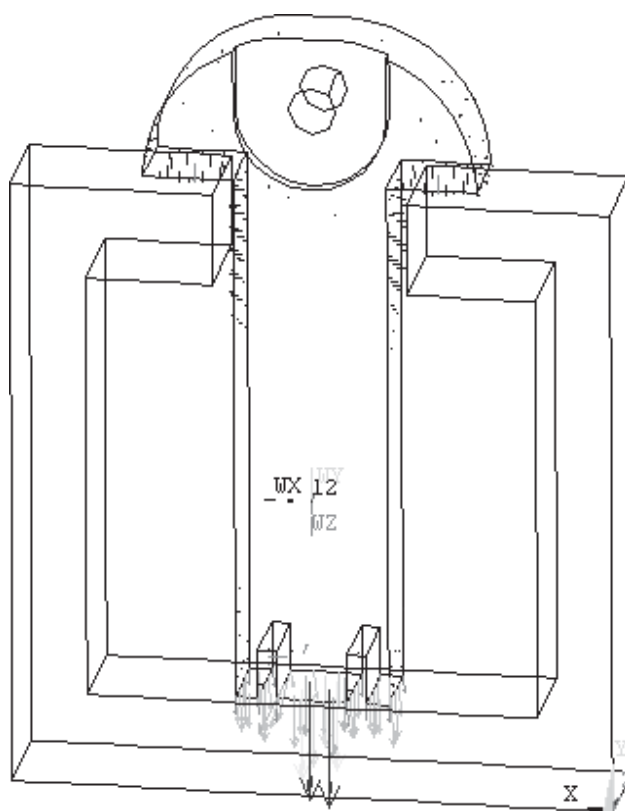

Fig.10 - Symmetry plane-view mesh model building
Edge formulation



0 0.15 0.30 0.45 0.60 0.74 0.88 1.03 1.18 1.33 T

Fig.11 - Magnetic field density on the symmetry plane and lateral faces (0.5 mm, 575 A, Edge Formulation)



0 0.1 0.2 0.3 0.4 0.5 0.6 0.7 0.8 0.9 N

Fig.12 - Static electromagnetic force vectors representation (0.5 mm, 575 A, Edge Formulation)

DISCUSSION

The percentage errors of the three numerical solutions related to measurements have been calculated.

As Figure 13 shows, for air gap greater than 2 mm the most precise solution is given by edge formulation with an average relative error of 5.6 % and for air gap less than 2 mm, the Virtual Work technique of MSP formulation agree better with experimental values, with an average relative error of 4.1 %.

For m.m.f. less than 400 A, the smallest errors are given again by the edge formulation, about -1.8 % and for m.m.f. greater than 400 A, by Virtual Work technique of MSP formulation, about 9.4 % (Figure 14). In both analysis, Maxwell technique of MSP formulation presents a constant relative error, about -34.1 %.

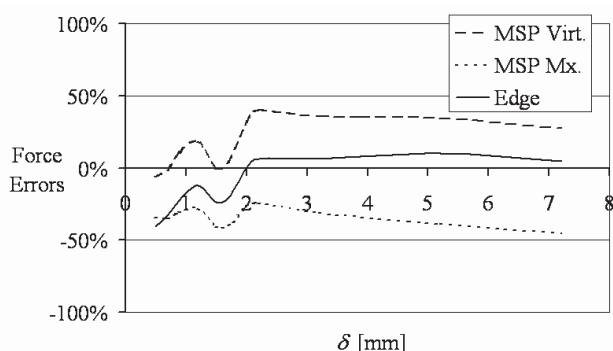

Fig.13 - Percentage errors comparison depending on the air gap

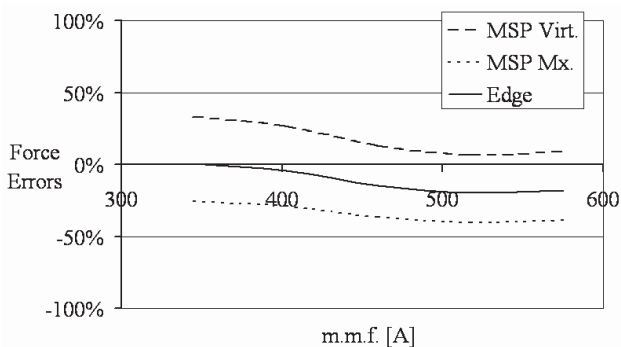

Fig.14 - Percentage errors comparison depending on the m.m.f.

CONCLUSIONS

Two formulations and three numerical solutions of static force characteristics of a plunger-type electromagnet are obtained: Magnetic Scalar Potential

Formulation with both techniques - virtual work and Maxwell, and edge formulation. Their performance are analysed using the 3D Finite Element Method and ANSYS® program. The different approaches have different behaviour with variation of the air gap and m.m.f. The edge element formulation gives best results among the three approaches both as average and maximal error with respect to the experiment.

REFERENCES

- [1] N. Takahashi, T. Nakata, H. Morishige: "Summary of Results for Problem 20 (3D Static Force Problem)", *Compel*, 1992, Vol. 14, Nos. 2&3, pp. 57-75.
- [2] D-H. Kim, D. A. Lowther, J. K. Sykulski: "Efficient Force Calculations Based on Continuum Sensitivity Analysis", *IEEE Transaction on Magnetics*, Vol. 41, No. 5, 2005, pp. 1404-1407.
- [3] J.-L. Coulomb and G. Meunier: "Finite Element Implementation of Virtual Work Principle for Magnetic for Electric Force and Torque Calculation", *IEEE Transactions on Magnetics*, Vol. Mag-20, No. 5, 1984, pp. 1894-1896.
- [4] Gyimesi, M., Avdeev, I., and Ostergaard, D.: "Finite Element Simulation of Micro Electro Mechanical Systems (MEMS) by Strongly Coupled Electro Mechanical Transducers", *IEEE Transactions on Magnetics*, Vol. 40, No. 2, 2004, pp. 557-560.
- [5] K. M. Prasad, K. R. Davey: "A boundary element analysis of team problem No.20: Static force calculation", 4-th International TEAM Workshop, 1993.
- [6] V. Spasov: "Computation of electromagnetic force by the nodal force method", 14-th International Symposium on Electrical Apparatus and Technologies - SIELA 2005, Vol. 2, 2005, pp. 139-144.
- [7] "ANSYS Release 9.0 Documentation", 2004.

Alin-Iulian I. Dolan was born in Craiova (Romania) in 1971. His educational background counts:

- Electrical Engineering Degree, Electrotechnical Faculty, University of Craiova, Romania, 1995;
- Master Degree, Electrotechnical Faculty, University of Craiova, Romania, 1996. From 1999, he works as assistant professor at University of Craiova, Electrotechnical Faculty.



Since 2004, he is PhD student in Engineering Doctoral School for Development - RENED, Technical University of Sofia, studying the modelling of electric, magnetic and thermal fields as well as transient phenomena in electrical equipments.

